

The World Market for Mass Flow Controllers, 3rd Edition

Proposal



**Publication Date:
Q3 2018**

www.FlowMFC.com



Flow Research, Inc.
27 Water Street
Wakefield, MA 01880
United States
+1 781-245-3200
+1 781-224-7552 (fax)
www.flowresearch.com



Flow Research, Inc.
 27 Water Street
 Wakefield, MA 01880
 United States
 +1 781-245-3200
 +1 781-224-7552 (fax)
www.flowresearch.com

The World Market for Mass Flow Controllers, 3rd Edition Proposal

The World Market for Mass Flow Controllers, 3rd Edition will analyze the state of the market for mass flow controllers. The study will provide updates to key segmentations of this market, using a base year of 2017 with forecasts through 2022. This study will be an update to our previous studies of the MFC market completed in 2008, 2012 and 2015, and will take into account recent technological innovations as well as describe the dynamic business environment that exists today.

Important segmentation will include total worldwide market size broken down by eight geographic regions, market share data, and technology analyses of the basic MFC types (Thermal, Pressure, Coriolis, and Ultrasonic). Because MFCs are used to both measure and control fluid flows, the study will identify their use by fluid type (Gases, Vapors, Liquids, and Slurries). The study will also determine the industries and applications where MFCs are found, and quantify their presence within each category. Average selling prices will be included and provided on a worldwide, geographic region, and key technology type basis.

All of the above data and more will be used to build specific marketing strategies for suppliers. Manufacturer supplier profiles will be included for all major market participants. The main goal of the study is to determine the size of the mass flow controller market in 2017, and to forecast market size through 2022.

The study will accomplish several important objectives:

- To determine the 2017 market size in US dollars and unit volumes for mass flow controllers worldwide, both thermal and non-thermal types
- To determine the 2017 market shares of leading suppliers of mass flow controllers worldwide
- To forecast market growth for all types of mass flow controllers through 2022
- To identify industries and applications where mass flow controllers are used, and to identify growth areas
- To provide a product analysis for the main manufacturer suppliers selling into the mass flow controller market
- To provide strategies to manufacturers for selling into the mass flow controller market
- To provide company profiles of the main suppliers of mass flow controllers

A number of suppliers have asked us to do this 3rd Edition study because the market has changed substantially since our last study was published in 2015. New environmental applications such as fuel cells and solar/photovoltaic have opened up new application avenues for mass flow controllers. The push for automation in factories will continue to favor the installation of MFCs. And growth in the emerging markets of China, India, Australia, Indonesia, and Malaysia will continue to drive growth in the mass flow controller market.

The semiconductor market continues to be cyclical in nature, but is still the dominant industry for mass flow controllers. This study sizes the semiconductor market, and also provides market shares for suppliers to this large market. However, the study has a special emphasis on the industrial segments that provide applications for mass flow controllers outside the semiconductor market. Some of these segments are faster growing than semiconductor, and hold the promise of longterm applications for MFCs. In addition, they are not cyclical in the way that semiconductor is, so they can provide some predictability for companies that want more stable sales growth.

There is a great deal of new segmentation in this study. This includes petroleum-based liquids, non-petroleum-based liquids, air, and gases, along with shipments by industrial segments. We are also including breakouts of MFCs by flowrates, by wetted material type, and by communication protocols. All in all, this study is more comprehensive than the last study, and is also very timely given the growth in the semiconductor and industrial segment markets.

Rationale for Study

We are doing a study that includes both the semiconductor, industrial, and lab/research markets for mass flow controllers (MFCs). In our 2015 study, much of the MFC market was found in the semiconductor market. We expect to find continued growth in these markets, as more companies offer products in this space. However, the semiconductor market grew substantially in 2017, and our new study will capture this growth. The semiconductor market is notoriously cyclical, and suppliers to it have historically experienced the same uneven fortunes in nearly direct proportion to their reliance upon it. On the other hand, the growth in the semiconductor market is likely to make the total MFC market size larger than projected in the previous study.

The study divides the worldwide market into the following geographic regions:

- North America (United States and Canada)
- Western Europe
- Eastern Europe, Former Soviet Union
- Middle East/Africa
- Japan
- China
- Asia/Pacific
- Latin America (Mexico, Central and South America)

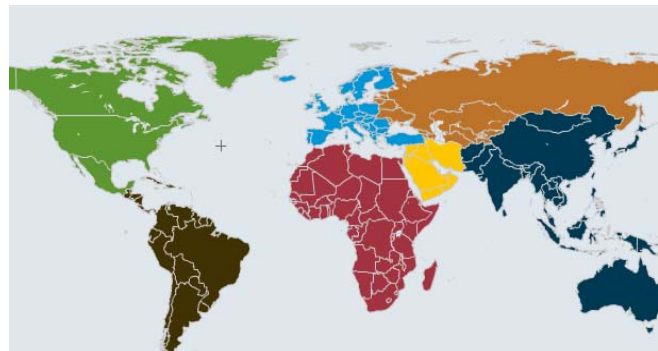

Primary Segmentation

Shipments of Mass Flow Controllers by Technology Worldwide and by Region:

- Thermal
- Differential Pressure (DP)
- Coriolis
- Ultrasonic

Shipments of Mass Flow Controllers by Type Worldwide and by Region

- Semiconductor
- Industrial
- Laboratory/Research

→ The completed study will segment the above industries by the eight geographic regions, providing both revenues and unit sales for each.

Shipments of Mass Flow Controllers by Industrial Segment

We have identified the following industrial segments as ones where MFCs are typically used:

- | | |
|-----------------------------|----------------------|
| • Aerospace | • Gas Distribution |
| • Analytical/Gas Analyzers | • Heat Treating |
| • Automotive | • LED Lighting |
| • Biotech/Pharmaceutical | • Medical |
| • Chemical/Petrochemical | • Metals Processing |
| • Electronics Manufacturing | • Packaging |
| • Fiber Optics/Glass | • Power |
| • Food & Beverage | • Solar/Photovoltaic |
| • Fuel Cells | • Other |
| • Furnaces | |

Shipments of Mass Flow Controllers by Control Function Worldwide and by Region

- With Control Function
- Flowmeter Only

→ This study will identify those mass flowmeters that are shipped as controllers, and those that are shipped as flowmeters without control.

Shipments of Mass Flow Controllers by Flowrate

- | | |
|------------------|--------------------|
| • <10 sccm | • >50 – 100 slpm |
| • 10 – 1000 sccm | • >100 – 200 slpm |
| • 1 – 10 slpm | • >200 – 500 slpm |
| • >10 – 30 slpm | • >500 – 1000 slpm |
| • >30 – 50 slpm | • >1000 slpm |

Average Selling Price of Mass Flow Controllers Worldwide and by Region

- The average selling price of mass flow controllers worldwide and by region
- The average selling price of mass flow controllers by industry type

Shipments of Mass Flow Controllers by Fluid Type

- Gas
- Air
- Petroleum Liquids
- Non-Petroleum Liquids

Shipments of Mass Flow Controllers by Wetted Material Type

- Stainless Steel (all grades)
- PTFE (Teflon)
- Aluminum
- Plastic

Shipments of Mass Flow Controllers by Communication Type

- Analog: 0-5 Vdc
- Analog: 4-20 mA
- Digital: All types including RS485, DeviceNet, Profibus, Modbus, and FOUNDATION™ Fieldbus
- **Other**

Shipments of Mass Flow Controllers by Distribution Channel Worldwide and by Region

- Direct Sales
- Independent Representatives
- Distributors
- Resellers (e.g. private label, catalog)
- E-Business

Shipments of Mass Flow Controllers by Customer Type Worldwide and by Region

- End-User
- Original Equipment Manufacturers (OEMs)
- Systems Integrators
- Engineering Companies



Company Profiles

This study will include extended profiles of companies that manufacture and supply into the Mass Flow Controller market on a worldwide or regional basis. These profiles include essential business data, company histories, organization and/or subsidiary summaries, product line descriptions, marketing goals and strategies, and related essential information.

Below is a partial list of companies to be profiled in this edition of *The Worldwide Market for Mass Flow Controllers*.

- Alicat Scientific
- Azbil
- Bronkhorst
- Brooks Instrument
- Bürkert
- Hitachi Metals Ltd. (including Aera[®])
- Horiba
- Kofloc
- Lintec
- Micro Motion
- MKS Instruments, Inc.
- Parker Hannifin
- Sierra Instruments
- Teledyne Hastings

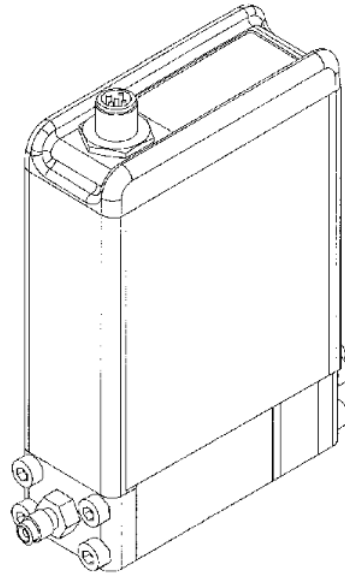

Background

Dr. Jesse Yoder is President of Flow Research Inc., a company he founded in 1998. Dr. Yoder has 30 years' experience as a writer and analyst in process control and instrumentation. Since 1990, he has written over 260 market research studies, most of them in flow and instrumentation, and has published nearly 300 articles. He recently wrote a book with Dick Morley called *The Tao of Measurement*. It was published in 2015 by the International Society of Automation (ISA). Dr. Yoder holds two U.S. patents on a dual tube flowmeter, granted in 2015 and 2017.

Norm Weeks, Senior Market Analyst, joined Flow Research in 2004 after a 24-year stint with Verizon. At Verizon, Norm specialized in creating innovative solutions for national and international enterprises, introducing new products and lifecycle management. At Flow Research, his contributions in development, research, and writing have been significant to studies, custom projects, White Papers, and Worldflow's *Energy Monitor* and *Market Barometer*.

Leslie Buchanan, Research Associate, joined Flow Research in March 2010. She assists with research and writing for Flow Research studies and publications, develops and implements standards for publication formats, and assists with customer liaison and the contact database.

David Goldstein, Business Analyst, joined Flow Research in September 2016. David has an MBA from Boston University and 30 years of professional experience including various management positions in Sales and Marketing with consumer product companies. At Flow Research, he combines his market research and business analyst skills with his creativity and organizational abilities to assist in researching and writing for studies and projects.

Harry Lund, Sales Director, joined Flow Research in October 2016. He has 45 years experience in the flow measurement industry with several US and international corporations. At Flow Research, his experience and skills with people, products and the flow measurement business world are a valuable resource.

Vicki Tuck, Administrative Assistant, joined Flow Research in June, 2012. She has experience in both the fast-paced law firms of Boston, and in various nonprofit organizations. In addition to administrative support, she also collects news for Flow Research publications.

Flow Research studies contribute to an ongoing view of the flowmeter market

Listed below is a summary of Flow Research studies in process as well as studies completed during the last few years in the area of process control instrumentation. The studies below and others are further described at www.flowstudies.com. You can order many of these studies through our secure online store at www.flowstudy.com.

Recent and Currently Scheduled Flow Research Studies

Websites

New-Technology Flowmeter Studies

The World Market for Coriolis Flowmeters, 5 th Edition	www.flowcoriolis.com
The World Market for Magnetic Flowmeters, 6 th Edition	www.flowmags.com
The World Market for Ultrasonic Flowmeters, 5 th Edition	www.flowultrasonic.com
The World Market for Vortex Flowmeters, 5 th Edition	www.flowvortex.com
The World Market for Thermal Flowmeters, 2 nd Edition	www.flowthermal.com

Traditional Technology Flowmeter Studies

The World Market for Pressure Transmitters, 5 th Edition	www.pressureresearch.com
The World Market for Positive Displacement Flowmeters, 2 nd Edition	www.flowpd.com
The World Market for Turbine Flowmeters, 2 nd Edition	www.flowturbine.com

Emerging Technology

The World Market for Multiphase Flowmeters, 2 nd Edition	www.flowmultiphase.com
Multiphase: Module A: The World Market for Watercut Meters	www.watercutmeters.com

Mass Flow Controllers

The World Market for Mass Flow Controllers, 3 rd Edition	www.flowmfc.com
The World Market Update for Mass Flow Controllers	www.flowmfc.com

Cross-Technology Flowmeter Studies

Volume X: The World Market for Flowmeters, 6 th Edition	www.flowvolumex.com
Volume X: Module A: Strategies, Industries, and Applications	www.flowvolumex.com
The World Market for Natural Gas and Gas Flow Measurement, 3 rd Edition	www.gasflows.com
The World Market for Oil and Oil Flow Measurement	www.oilflows.com

Custom work, user surveys, and other market news and analysis

In addition to the flowmeter studies listed above, Flow Research has done studies on other technologies and topics such as temperature sensors and transmitters, level devices, flow calibration facilities, and the oil and gas markets.

Flow Research's **Worldflow Monitoring Service** provides quarterly updates on the instrumentation and energy industries in the publications **Market Barometer** and **Energy Monitor**. The *Market Barometer* covers news and analysis related to flowmeters, level measurement devices and some other process industries instrumentation, plus flow calibration. The *Energy Monitor* covers news and analysis related to the oil & gas, refining, power, and renewables industries. More details are available at www.worldflow.com.

Beside off-the-shelf studies, Flow Research specializes in **custom projects** for companies or others who want more detailed information on a specific subject. Custom reports are often commissioned by companies who are evaluating the future of a product line or an expansion of their product line, determining whether to make an acquisition or merge with another company, seeking to understand their customer needs better, or other specific needs.

We also conduct **user surveys** that include a detailed analysis of customer perceptions. User surveys can be useful to reveal hidden problems, emerging applications, and new product requirements. We gather the data and analyze it in light of our wealth of knowledge on instrumentation and markets. We then formulate strategies that help you achieve your goals.

For more information on Flow Research, please visit our website at www.flowresearch.com.

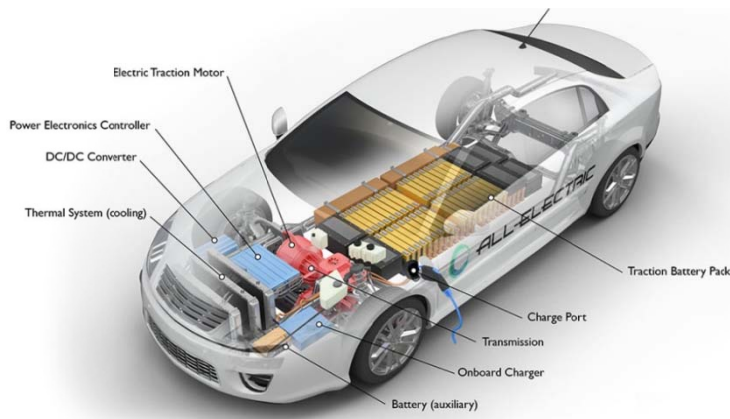

A typical design for an all-electric fuel cell powered automobile

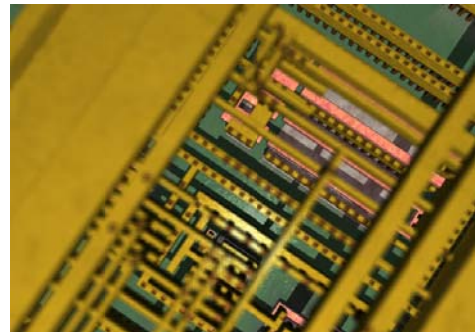

*An image of a silicon chip
(Author: David Carron)*



Flow Research, Inc.
 27 Water Street
 Wakefield, MA 01880
 +1 781 245-3200
 +1 781 224-7552 (fax)
www.flowresearch.com



Christian Doppler

The Flow Research Founding Sponsor Program

To produce studies that most closely match our clients' needs, Flow Research instituted the Founding Sponsor Program. This program enables companies who wish to participate at a high level in a study's research to influence its scope and segmentation. In addition, Founding Sponsors receive regular updates from Flow Research on study progress, and receive a significant discount on the standard retail price of the study.

Procedure: Early in the planning phase of a study, Founding Sponsors receive a proposal that includes the proposed segmentation. Founding Sponsors can propose additional segmentation, and can also suggest changes to the proposed segmentation. While the decision to adopt particular segmentation ultimately lies with Flow Research, and is based on input from all contributors, we will do our best to accommodate the specific needs of each of our clients.

During the research phase of a study, Flow Research will issue regular reports that provide updates on the progress of the research. These reports will be sent to Founding Sponsors, who are then invited to provide any additional input or comments into the study.

Being a Founding Sponsor requires making an early commitment to purchase the study. However, in return, Founding Sponsors receive a significant discount off the regular price of the study. Payment can be made either in one amount at the beginning of the study, or split into two, with the second payment due upon delivery of the study.

For additional details, or to find out how the Founding Sponsor program applies to any particular study, please contact Flow Research. We look forward to working with you!

If you have any questions about the Founding Sponsor program, please contact Norm Weeks at +1 781 245-3200, or norm@flowresearch.com.

The World Market for Mass Flow Controllers, 3rd Edition

Proposal



www.FlowMFC.com



Flow Research, Inc.
27 Water Street
Wakefield, MA 01880
United States
+1 781-245-3200
+1 781-224-7552 (fax)
www.flowresearch.com

We create change in flow